

ACTIVE SAFETY

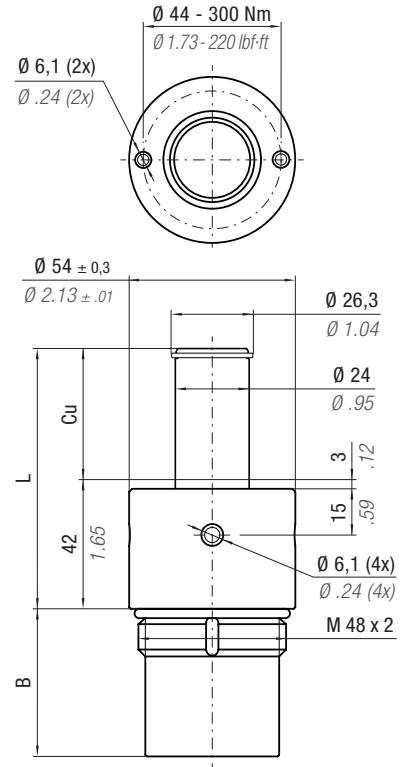
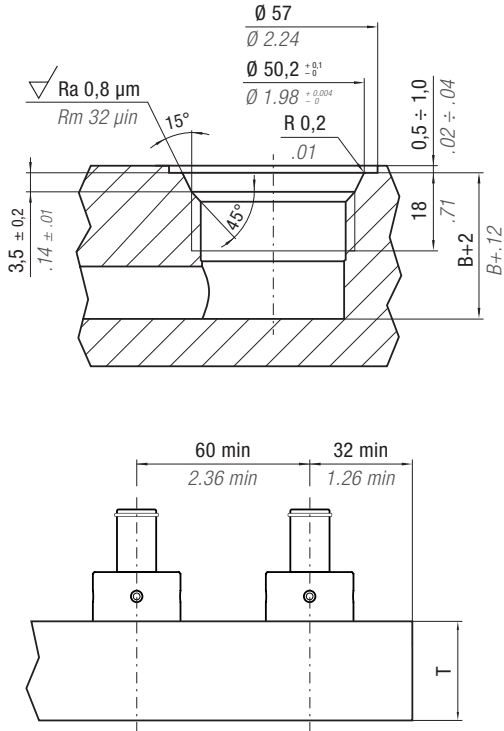

Max Speed	Temperature	Gas	P max	P min	S	Accessories
158 ft/min 0.8 m/s	32 - 176 °F 0 - 80 °C	N ₂	1595 psi 110 bar	290 psi 20 bar	1.49 in ² 9.62 cm ²	Y, Z, X CAD

PART NUMBER	Fo		Cu		L		B		T		Weight	
	ton	daN	inch	mm	inch	mm	inch	mm	inch	mm	~ lb	~ Kg
CB 1000 - 025 - A	1.06	1060	0.98	25	2.64	67	0.91	23	1.69	43	1.81	0.82
CB 1000 - 038 - A			1.50	38	3.15	80	1.42	36	1.89	48	2.03	0.92
CB 1000 - 050 - A			1.97	50	3.62	92	1.89	48	2.36	60	2.23	1.01
CB 1000 - 075 - A			2.95	75	4.61	117	2.87	73	3.35	85	2.65	1.20
CB 1000 - 100 - A			3.94	100	5.59	142	3.86	98	4.33	110	3.08	1.40
CB 1000 - 150 - A			5.91	150	7.56	192	5.83	148	6.30	160	3.92	1.78

HOW TO ORDER p. 39	ACCESSORIES p. 47	SERVICE TOOLS p. 68 Part Number 58UT051A or 58UT054A	MAINTENANCE KIT Part Number 39BMCB02500A
------------------------------	-----------------------------	--	--