



SW

ACTIVE SAFETY



OSAS

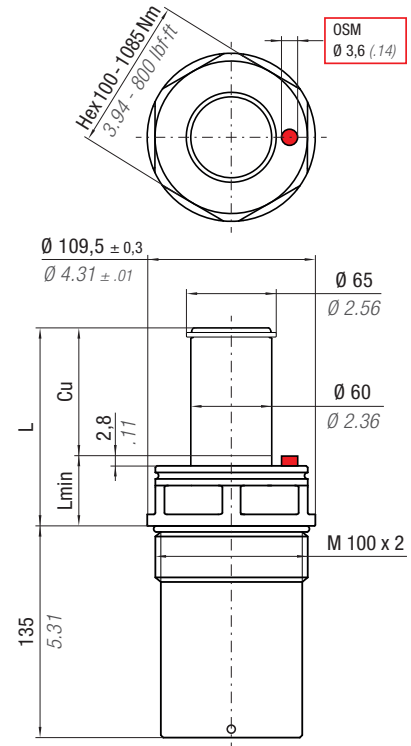
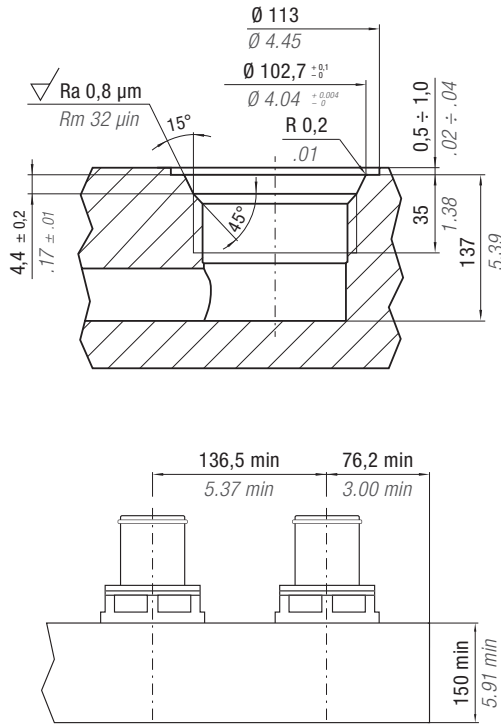

<b>Max Speed</b> 315 ft/min 1,6 m/s	32 - 176 °F 0 - 80 °C	N <sub>2</sub>	<b>P max</b> 2175 psi 150 bar	<b>P min</b> 363 psi 25 bar	<b>S</b> 7.791 in <sup>2</sup> 50,26 cm <sup>2</sup>	HX CAD
---	--------------------------	----------------	-------------------------------------	-----------------------------------	--	-----------

PART NUMBER	F <sub>0</sub> Initial Force		Cu		L		L min			
	inch	mm	inch	mm	inch	mm	inch	mm	~ lb	~ Kg
CR 7700 - 100 - A	6.44 ton - 6440 daN	7.73 ton - 7730 daN	3.94	100	5.31	135	1.38	35	17.41	7.90
CR 7700 - 125 - A			4.92	125	7.28	185	2.36	60	20.50	9.30
CR 7700 - 160 - A			6.30	160	10.04	255	3.74	95	24.82	11,26
CR 7700 - 200 - A	1813 psi 125 bar	2175 psi 150 bar	7.87	200	13.19	335	5.31	135	29.76	13,50
CR 7700 - 250 - A			9.84	250	17.13	435	7.28	185	35.93	16,30

<b>HOW TO ORDER</b> p. 17	<b>ACCESSORIES</b> p. 47	<b>SERVICE TOOLS</b> p. 68 Part Number 58UT048A	<b>MAINTENANCE KIT</b> Part Number 39BMCR08000A
------------------------------	-----------------------------	--	--