

CODE	Reference to standards	A		B		C		D		Ø E		Ø F		Ø G	
		mm	inch	mm	inch	mm	inch	mm	inch	mm	inch	mm	inch	mm	inch
FS3 19	0	45	1.77	25	0.98	32	1.26	9,2	0.36	7	0.28	19,3	0.76	21,4	0.84
FS3 25	0	50	1.97	30	1.18	38	1.50	9,2	0.36	7	0.28	25,3	1.00	27,4	1.08

# FCA

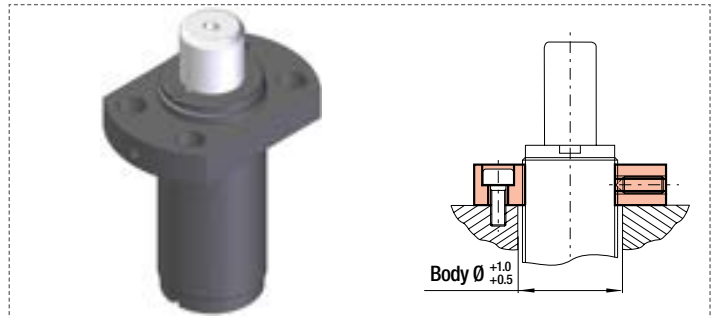
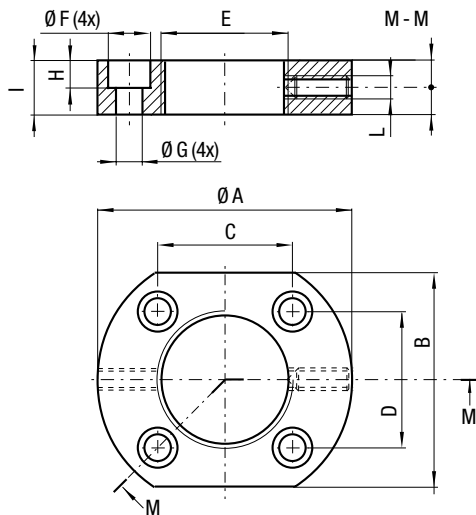

CODE	Reference to standards	Ø A		B		C		D	E	Ø F		Ø G		H		I		L	
		mm	inch	mm	inch	mm	inch			mm	inch	mm	inch	mm	inch	mm	inch		
FCA 38	0	75	2.95	50	1.97	50,3	1.98	29	1.14	M 38 x 1,5	14	0.55	9	0.35	8	0.31	12	0.47	M6
⚠ FCA 45	0	90	3.54	60	2.36	60	2.36	34	1.34	M 45 x 1,5	14	0.55	9	0.35	8	0.31	16	0.63	M6
⚠ FCA 50	0-22	100	3.94	66	2.60	66	2.60	38	1.50	M 50 x 1,5	14	0.55	9	0.35	8	0.31	16	0.63	M6

⚠ Phasing out