

CODE	Reference to standards	A		B		C		D		E		Ø F		Ø G		Ø H		J		K	
		mm	inch	mm	inch	mm	inch	mm	inch	mm	inch	mm	inch	mm	inch	mm	inch	mm	inch	mm	inch
FSE45	0	100	3.94	60	2.36	30	1.18	20	0.79	70	2.76	45,3	1.78	11	0.43	18	0.71	10	0.39	25	0.98

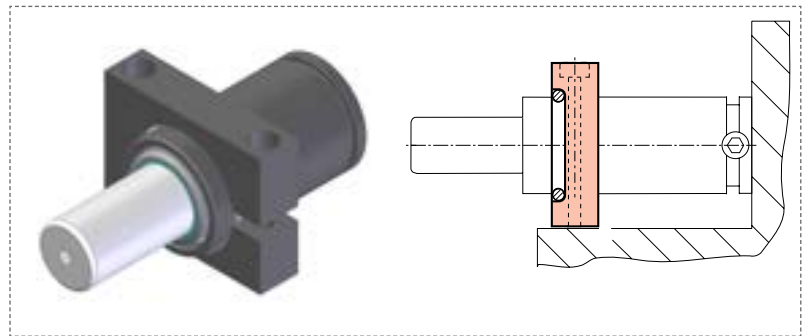
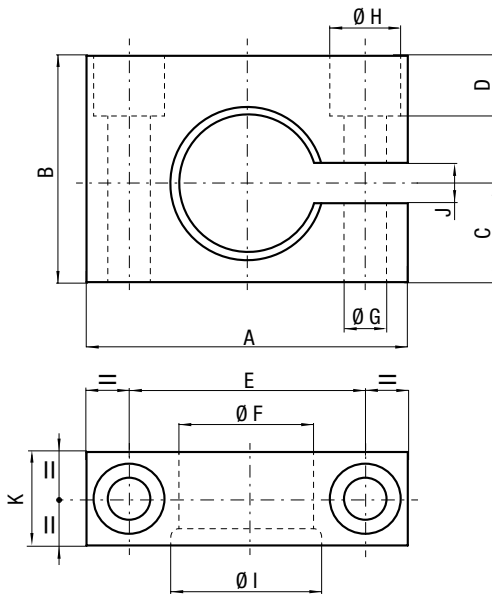

CODE	Reference to standards	A		B		C		D		E		Ø F		Ø G		Ø H		Ø I		J		K	
		mm	inch	mm	inch	mm	inch	mm	inch	mm	inch	mm	inch	mm	inch	mm	inch	mm	inch	mm	inch	mm	inch
FSE50	11	90	3.54	70	2.76	30	1.18	25	0.98	68	2.68	50,3	1.98	11	0.43	18	0.71	54,1	2.13	10	0.39	30	1.18
FSE75	11	125	4.92	94	3.70	42	1.65	19	0.75	100	3.94	75,3	2.96	13	0.51	20	0.79	80,1	3.15	10	0.39	30	1.18
FSE95	11	140	5.51	115	4.53	52,5	2.07	40	1.57	115	4.53	95,3	3.75	13	0.51	20	0.79	100,1	3.94	10	0.39	30	1.18