



ACTIVE SAFETY



OSAS



USAS



OPAS

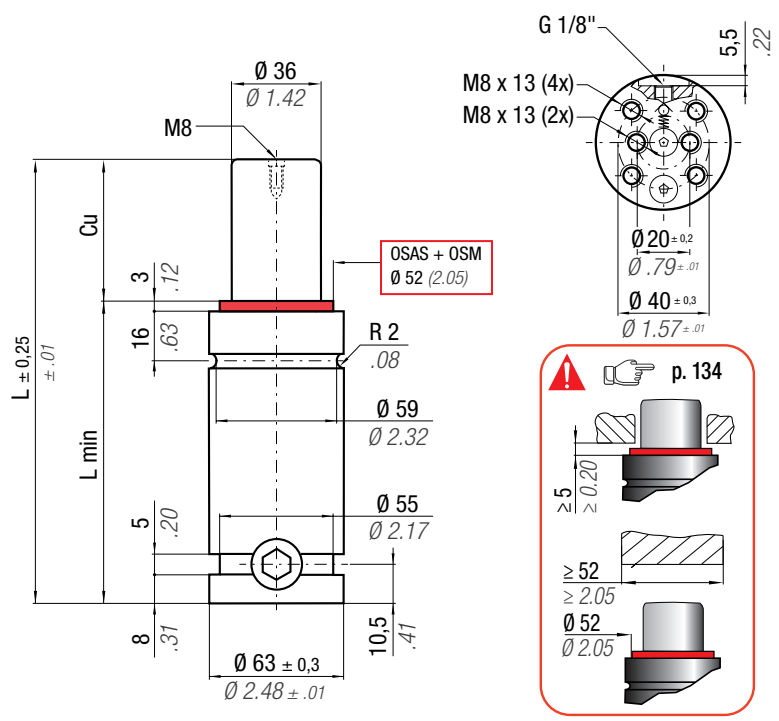

OSAS + OSM = OVER STROKE ACTIVE SAFETY + OVER STROKE SAFETY MARKER

Il nuovo codice sarà fornito solo ad esaurimento del vecchio
The new code will be supplied only when the old will be out of stock

Der neue Kode wird nur angegeben, wenn der alte nicht mehr lieferbar ist

Le nouveau code sera fourni uniquement lorsque le vieux stock sera écoulé

El nuevo código será suministrado sólo cuando se agoten las existencias del antiguo

O novo código irá ser fornecido apenas quando o antigo esgotar stock

easu MANIFOLD p. 247

* F_{1i} = Isothermal end force at 100% Cu p. 16
** F_{1p} = Polytrophic end force at 100% Cu

N ₂	0 - 80 °C 32 - 176 °F	ΔP ± 0,33 %/°C	P max 150 bar 2175 psi	P min 20 bar 290 psi	S 10,17 cm ² 1.576 in ²	SPM ~ 15 - 100 (at 20°C)	Max Speed 1,8 m/s 70.8 in/s	Maintenance kit 39BMH01500C Cu 25 ÷ 80 39BMH01500CH Cu 100 ÷ 300
----------------	--------------------------	---------------------------	-------------------------------------	-----------------------------------	--	---------------------------------------	--	---

CODE PHASING OUT from 04/2021	NEW	Cu		L		L min		F ₀ Initial force		F _{1i} * End force *		F _{1p} ** End force **		V ₀		PED 2014/68/EU																																																																			
		mm	inch	mm	inch	mm	inch	daN	lb	daN	lb	daN	lb	cm ³	in ³	~Kg	~lb	✓																																																																	
H 1500 - 013 - C	◆ H 1500 - 013 - D	13	0,51	120,7	4,75	107,7	4,24	1530 3440 ± 5%	1982 4456	2260 5081	67 4,10	1,98 4,37	✓																																																																						
H 1500 - 025 - C	H 1500 - 025 - D	25	0,98	145	5,71	120	4,72							2177 4895	2560 5755	99 6,02	2,13 4,70	✓																																																																	
H 1500 - 038 - C	H 1500 - 038 - D	38	1,50	171	6,73	133	5,24												2306 5183	2762 6210	132 8,06	2,29 5,05	✓																																																												
H 1500 - 050 - C	H 1500 - 050 - D	50	1,97	195	7,68	145	5,71																	2383 5358	2887 6490	163 9,95	2,44 5,38	✓																																																							
H 1500 - 063 - C	H 1500 - 063 - D	63	2,48	221	8,70	158	6,22																						2443 5493	2983 6707	197 11,99	2,60 5,73	✓																																																		
H 1500 - 075 - C	H 1500 - 075 - D	75	2,95	245	9,65	170	6,69																											2484 5585	3050 6857	227 13,88	2,75 6,06	✓																																													
H 1500 - 080 - C	H 1500 - 080 - D	80	3,15	255	10,04	175	6,89																																2499 5617	3074 6910	240 14,66	2,81 6,19	✓																																								
H 1500 - 100 - C	H 1500 - 100 - D	100	3,94	295	11,61	195	7,68																																					2544 5720	3148 7078	292 17,80	3,03 6,68	✓																																			
H 1500 - 125 - C	H 1500 - 125 - D	125	4,92	345	13,58	220	8,66																																										2584 5809	3214 7224	356 21,73	3,34 7,36	✓																														
H 1500 - 150 - C	H 1500 - 150 - D	150	5,91	395	15,55	245	9,65																																															2612 5873	3260 7329	420 25,65	3,64 8,02	✓																									
H 1500 - 160 - C	H 1500 - 160 - D	160	6,30	415	16,34	255	10,04																																																				2621 5893	3275 7363	446 27,22	3,77 8,31	✓																				
H 1500 - 175 - C	H 1500 - 175 - D	175	6,89	445	17,52	270	10,63																																																									2633 5920	3295 7408	485 29,58	3,95 8,71	✓															
H 1500 - 200 - C	H 1500 - 200 - D	200	7,87	495	19,49	295	11,61																																																														2650 5957	3322 7469	549 33,51	4,26 9,39	✓										
H 1500 - 250 - C	H 1500 - 250 - D	250	9,84	595	23,43	345	13,58																																																																			2722 6119	3443 7740	661 40,36	4,99 11,00	✓					
H 1500 - 300 - C	H 1500 - 300 - D	300	11,81	695	27,36	395	15,55																																																																								2804 6303	3582 8052	764 46,59	5,81 12,81	✓

◆ Disposable

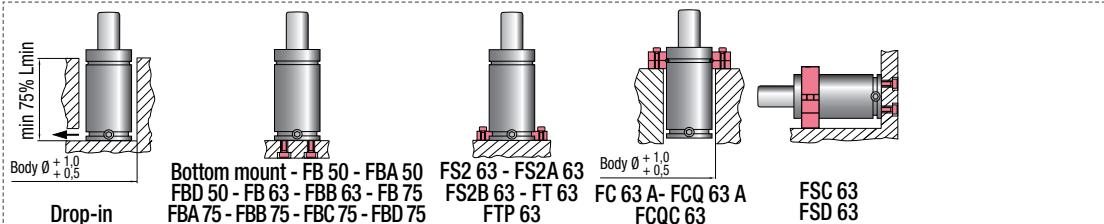

HOW TO ORDER p. 135
INSTALLATION GUIDELINE p. 205