

ISO 11901 - 4 39D 838 (VW)	VDI 3003 Blatt 4	B2 4008 (BMW)	075.90.65 (FCA)
-------------------------------	------------------	---------------	-----------------



**OSAS + OSM** = OVER STROKE ACTIVE SAFETY + OVER STROKE MARKER

## ACTIVE SAFETY



OSAS



USAS



OPAS

Il nuovo codice sarà fornito solo ad esaurimento del vecchio  
The new code will be supplied only when the old will be out of stock  
Der neue Kode wird nur angegeben, wenn der alte nicht mehr lieferbar ist  
Le nouveau code sera fourni uniquement lorsque le vieux stock sera écoulé  
El nuevo código será suministrado sólo cuando se agoten las existencias del antiguo  
O novo código irá ser fornecido apenas quando o antigo esgotar stock

**easu** MANIPOL p. 247

\*  $F_{1i}$  = Isothermal end force at 100% Cu p. 16

\*\*  $F_{1p}$  = Polytrophic end force at 100% Cu

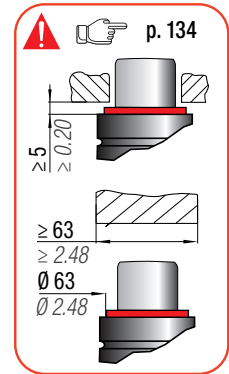
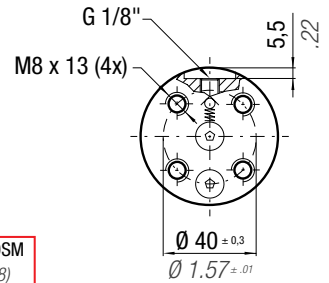
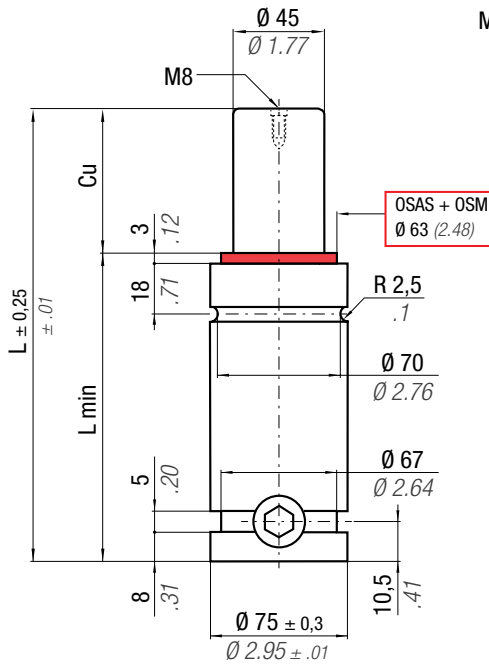

N <sub>2</sub>	0 - 80 °C 32 - 176 °F	$\Delta P$ $\pm 0,33 \% / ^\circ C$	P max 150 bar 2175 psi	P min 20 bar 290 psi	S 15,90 cm <sup>2</sup> 2.465 in <sup>2</sup>	SPM ~ 15 - 100 (at 20°C)	Max Speed 1,8 m/s 70.8 in/s	Maintenance kit 39BMH02400D Cu 25 ÷ 80 39BMH02400DH Cu 100 ÷ 300
----------------	--------------------------	--	------------------------------	----------------------------	---	--------------------------------	-----------------------------------	--

CODE PHASING OUT from 04/2021	NEW	Cu		L		L min		F <sub>0</sub>		F <sub>1i</sub> *		F <sub>1p</sub> **		V <sub>0</sub>		PED 2014/68/EU			
		mm	inch	mm	inch	mm	inch	daN	lb	daN	lb	daN	lb	cm <sup>3</sup>	in <sup>3</sup>		~Kg	~lb	
H 2400 - 025 - D	H 2400 - 025 - E	25	0.98	160	6.30	135	5.31	2385	5362	± 5%	3282	7378	3814	8574	169	10.32	3,34	7.36	✓
H 2400 - 038 - D	H 2400 - 038 - E	38	1.50	186	7.32	148	5.83				3495	7857	4146	9321	220	13.44	3,55	7.83	✓
H 2400 - 050 - D	H 2400 - 050 - E	50	1.97	210	8.27	160	6.30				3632	8165	4363	9807	267	16.31	3,75	8.27	✓
H 2400 - 063 - D	H 2400 - 063 - E	63	2.48	236	9.31	173	6.81				3741	8410	4537	10200	318	19.42	3,96	8.73	✓
H 2400 - 075 - D	H 2400 - 075 - E	75	2.95	260	10.24	185	7.28				3818	8583	4662	10480	366	22.30	4,15	9.15	✓
H 2400 - 080 - D	H 2400 - 080 - E	80	3.15	270	10.63	190	7.48				3845	8644	4706	10579	385	23.50	4,23	9.33	✓
H 2400 - 100 - D	H 2400 - 100 - E	100	3.94	310	12.20	210	8.27				3933	8842	4850	10902	464	28.29	4,51	9.94	✓
H 2400 - 125 - D	H 2400 - 125 - E	125	4.92	360	14.17	235	9.25				4012	9019	4979	11192	562	34.28	4,91	10.82	✓
H 2400 - 150 - D	H 2400 - 150 - E	150	5.91	410	16.14	260	10.24				4068	9146	5072	11402	660	40.28	5,32	11.73	✓
H 2400 - 160 - D	H 2400 - 160 - E	160	6.30	430	16.93	270	10.63				4087	9187	5103	11471	699	42.68	5,49	12.10	✓
H 2400 - 175 - D	H 2400 - 175 - E	175	6.89	460	18.11	285	11.22				4111	9243	5144	11563	758	46.27	5,73	12.63	✓
H 2400 - 200 - D	H 2400 - 200 - E	200	7.87	510	20.08	310	12.20				4145	9319	5200	11690	856	52.26	6,14	13.54	✓
H 2400 - 250 - D	H 2400 - 250 - E	250	9.84	610	24.02	360	14.17				4195	9431	5283	11876	1053	64.25	6,95	15.32	✓
H 2400 - 275 - D	H 2400 - 275 - E	275	10.83	660	25.98	385	15.16				4214	9473	5314	11947	1151	70.24	7,36	16.23	✓
H 2400 - 300 - D	H 2400 - 300 - E	300	11.81	710	27.95	410	16.14				4230	9509	5341	12007	1249	76.22	7,77	17.13	✓

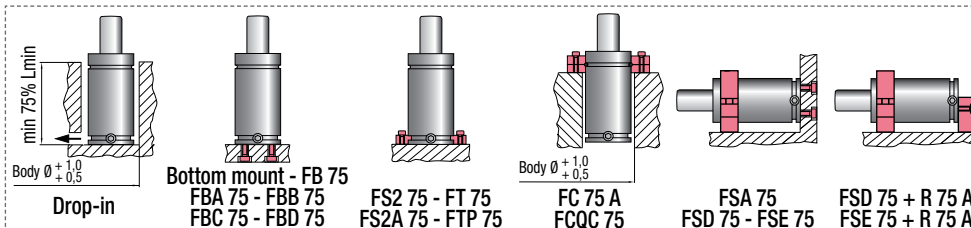

### HOW TO ORDER

p. 135

### INSTALLATION GUIDELINE

p. 205