

Il nuovo codice sarà fornito solo ad esaurimento del vecchio - The new code will be supplied only when the old will be out of stock - Der neue Kode wird nur angegeben, wenn der alte nicht mehr lieferbar ist - Le nouveau code sera fourni uniquement lorsque le vieux stock sera écolulé - El nuevo código será suministrado sólo cuando se agoten las existencias del antiguo - O novo código irá ser fornecido apenas quando o antigo esgotar stock

ACTIVE SAFETY



OSAS



USAS



OPAS

* $F_{1i} =$

Isothermal end force at 100% Cu



p. 16



** $F_{1p} =$

Polytropic end force at 100% Cu



Collegabile con tubi - Linkable with hoses
Anschlussfähig mit Leitungen
Connectable with tubes - Conectable con mangueras
Acompláveis com tubos

Micro 32°

Force color code	P		F0	
	bar	psi	Initial force ± 5% at +20°C	+68°F
			daN	lb
OR	10	145	5	11
PR	20	290	10	22
GR	60	870	30	67
BU	100	1450	50	112
RD	140	2030	70	157
YW	180	2610	90	202
BK	10-180	145-2610	5-90	11-202

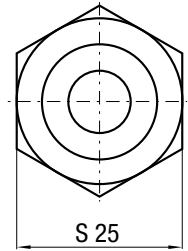
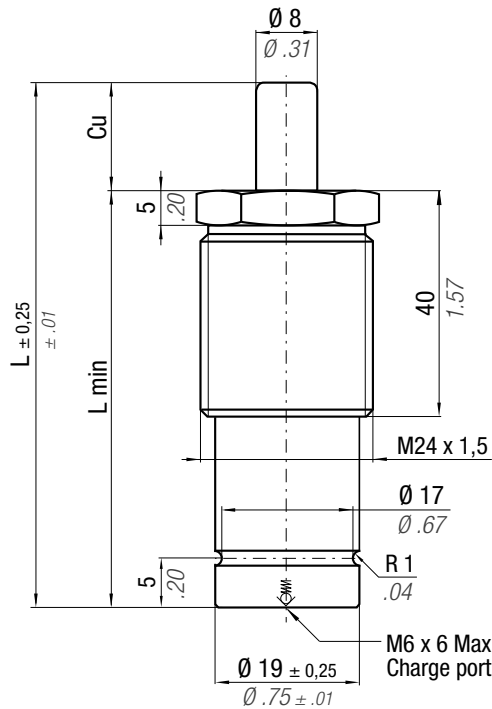

Senza riserva corsa
Without reserve of stroke
Ohne Hubreserve
Sans course de réserve
Sin margen de Carrera
Sem reserva de curso



NON superare 90% Cu
DO NOT exceed 90% Cu
NICHT überschreiten die 90% Cu
NE PAS dépasser 90% Cu
NO superar el 90% Cu
NÃO se excedam os 90% Cu

N ₂		0 - 80 °C 32 - 176 °F	ΔP ± 0,33 %/°C	P max 180 bar 2610 psi	P min 10 bar 145 psi	S 0,50 cm ² 0,078 in ²	SPM ~ 100 - 150 (at 20°C)	Max Speed 1,8 m/s 70,8 in/s	Maintenance kit Disposable			
CODE PHASING OUT from 05/2019	NEW	Cu	L	L min	F _{1i} *	F _{1p} **	V ₀	PED 2014/68/EU				
		mm	inch	mm	inch	mm	inch	cm ³	in ³	~Kg	~lb	
M90-007-A-...-TEM	M90-007-B-...-TEM	7	0.28	56	2.20	49	1.93	2,3	0.14	0,07	0.15	✓
M90-010-A-...-TEM	M90-010-B-...-TEM	10	0.39	62	2.44	52	2.05	2,9	0.18	0,07	0.15	✓
M90-013-A-...-TEM	M90-013-B-...-TEM	12,7	0.50	67,4	2.65	54,7	2.15	3,4	0.21	0,08	0.18	✓
M90-015-A-...-TEM	M90-015-B-...-TEM	15	0.59	72	2.83	57	2.24	3,9	0.24	0,08	0.18	✓
M90-025-A-...-TEM	M90-025-B-...-TEM	25	0.98	92	3.62	67	2.64	5,8	0.35	0,09	0.20	✓
M90-038-A-...-TEM	M90-038-B-...-TEM	38,1	1.50	118,2	4.65	80,1	3.15	8,4	0.51	0,11	0.24	✓
M90-050-A-...-TEM	M90-050-B-...-TEM	50	1.97	142	5.59	92	3.62	10,8	0.66	0,12	0.26	✓
M90-063-A-...-TEM	M90-063-B-...-TEM	63,5	2.50	172	6.77	108,5	4.27	13,7	0.84	0,14	0.31	✓
M90-080-A-...-TEM	M90-080-B-...-TEM	80	3.15	205	8.07	125	4.92	17	1.04	0,15	0.33	✓
M90-100-A-...-TEM	M90-100-B-...-TEM	100	3.94	245	9.65	145	5.71	20,9	1.28	0,17	0.37	✓
M90-125-A-...-TEM	M90-125-B-...-TEM	125	4.92	295	11.61	170	6.69	25,8	1.57	0,20	0.44	✓

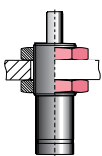

DM 24

HOW TO ORDER

p. 39

INSTALLATION GUIDELINE

p. 205