

PART NUMBER	FIG.	THREAD SIZE	O-RING (ONLY FOR REPLACEMENT)	H		Ø D		T		L		S		R		TOOL NEEDED
				inch	mm	inch	mm	inch	mm	inch	mm	inch	mm	inch	mm	
39TM001A	1	7/16-20	500RNE16A	0.19	5,0	0.56	14,0	0.11	3,0	0.36	9,0	-	-	-	-	3/16 Hex Head Allen Wrench
39TM002A	1	1/2-20	500R1501050	0.19	5,0	0.63	16,0	0.11	3,0	0.36	9,0	-	-	-	-	3/16 Hex Head Allen Wrench
39TM003A	1	3/4-16	500RIA01600	0.31	8,0	0.88	22,0	0.16	4,0	0.44	11,0	-	-	-	-	5/16 Hex Head Allen Wrench
39TM004A	1	7/8-14	500R2001900	0.38	10,0	1.00	25,0	0.16	4,0	0.50	13,0	-	-	-	-	3/8 Hex Head Allen Wrench
39TM005A	1	1 1/16-12	500R2502300	0.56	14,0	1.25	32,0	0.18	5,0	0.59	15,0	-	-	-	-	9/16 Hex Head Allen Wrench
39TM006A	1	1 -3/16-12	500R2502700	0.56	14,0	1.38	35,0	0.18	5,0	0.59	15,0	-	-	-	-	9/16 Hex Head Allen Wrench
39TM007A	1	1 5/16-12	500R2503000	0.63	16,0	1.50	38,0	0.18	5,0	0.59	15,0	-	-	-	-	5/8 Hex Head Allen Wrench
39TM008A	2	1 5/8-12	500R3003800	-	-	1.88	48,0	0.16	4,0	0.59	15,0	0.50	12,7	-	-	1/2 Sq. Drive Wrench
39TM009A	2	1 7/8-12	500R9364	-	-	2.12	54,0	0.16	4,0	0.59	15,0	0.50	12,7	-	-	1/2 Sq. Drive Wrench
39TM010A	2	M47x2	500R9364	-	-	2.12	54,0	0.16	4,0	0.59	15,0	0.50	12,7	-	-	1/2 Sq. Drive Wrench
39TM011A	3	2 1/2-12	500R9427	-	-	2.75	70,0	0.16	4,0	0.59	15,0	0.50	12,7	1.46	37	1/2 Sq. Drive Wrench
39TM012A	3	M63x2	500R9427	-	-	2.75	70,0	0.16	4,0	0.59	15,0	0.50	12,7	1.46	37	1/2 Sq. Drive Wrench
39TM013A	3	M82x2	500R3507800	-	-	3.50	89,0	0.25	6,0	0.75	19,0	0.75	19,1	1.97	50	3/4 Sq. Drive Wrench
39TM014A	3	M100x2	500R1016301	-	-	4.25	108,0	0.25	6,0	0.75	19,0	0.75	19,1	2.36	60	3/4 Sq. Drive Wrench

SERVICE TOOLS

PART NUMBER	FIG.	H		F		MANIFOLD CYLINDER PART NUMBER
		inch	mm	inch	mm	
58UT044A	1	1.50	38,0	0.75	19,1	CR 750 / CRD 750
58UT045A	1	1.97	50,0	0.75	19,1	CR 1500 / CRD 1500
58UT046A	1	2.56	65,0	1.00	25,4	CR 3000 / CRD 3000
58UT047A	1	3.23	82,0	1.00	25,4	CR 5000 / CRD 5000 / CR 5200
58UT048A	1	3.94	100,0	1.00	25,4	CR 8000 / CRD 8000 / CR 7700
58UT049A	1	4.72	120,0	2.50	63,5	CR 10700
58UT050A	2	-	-	-	-	CC 500
58UT051A	2	-	-	-	-	CC 1000 / CB 1000 / CC 2500 / CB 2500
58UT054A	3	-	-	-	-	CA 2500 / CC 500 / CC 1000 CB 1000 / CC 2500 / CB 2500

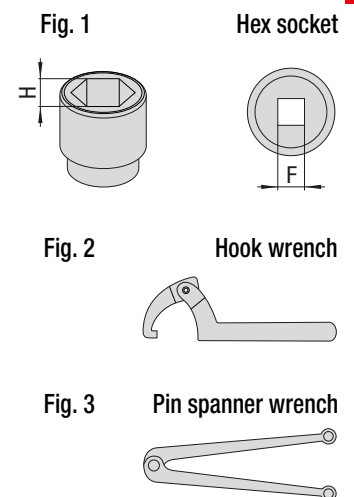

Part Number 58UT029A Padlock for discharge valve.

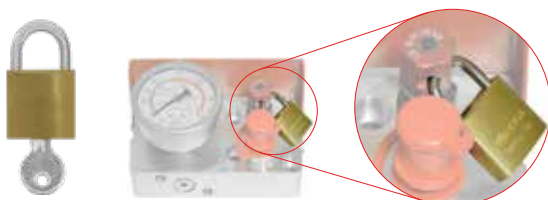

WHY TO USE IT

To prevent **UNauthorized** charging during maintenance.

BENEFITS

Safer maintenance and less accidents.

