

NE SERIES

NG SERIES

VDI	BMW	Ford
VW		



VDI	GM	FCA
-----	----	-----

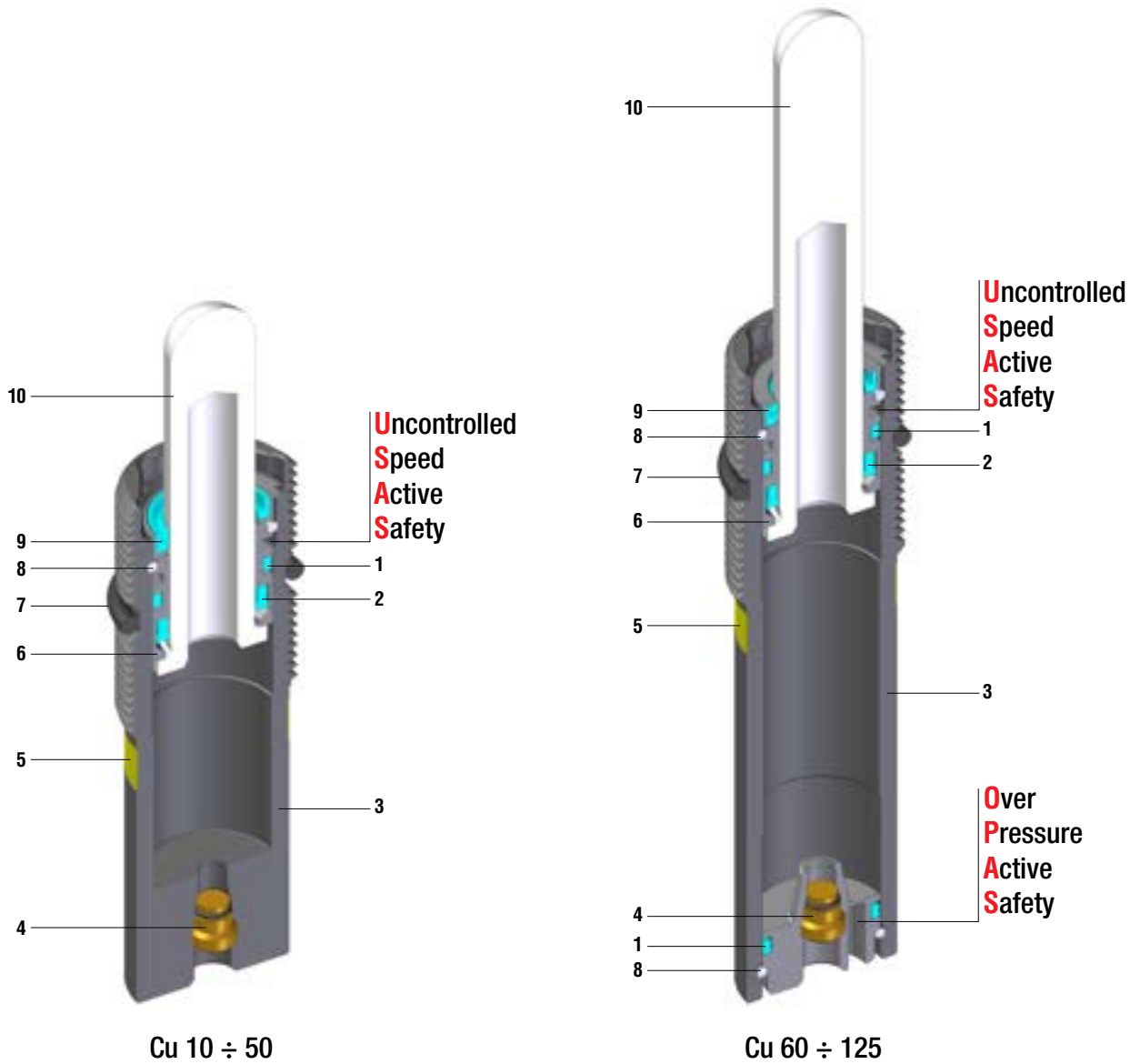





Espulsori a gas - Gas ejectors - Federnde Druckstücke
 Ejectores de gaz - Eyectores de gas - Eyectores a gás

SEALING	ROD SEAL
DESIGN	BUSH - BODY DESIGN

1	Dual ring seal	6	Bush
2	Rod seal	7	Locking ring
3	Body	8	Retaining ring
4	Valve	9	Rod wiper
5	Force color code	10	Rod (nitrited superfinished)

RANGE CHART

Model	Body Ø		Stroke Cu		Initial force F0		 OSAS	 USAS	 OPAS	 SKUDO
	mm	inch	mm	inch	daN	lb				
NE 16 x 1,5	M 16 x 1,5	M 16 x 1.5	10 - 125	0.39 - 4.92	3 - 42	7 - 95	-	✓	-	-
NE 16 x 2	M 16 x 2	M 16 x 2	10 - 125	0.39 - 4.92	3 - 42	7 - 95	-	✓	-	-
NG 16 x 1,5	M 16 x 1,5	M 16 x 1.5	10 - 100	0.39 - 3.94	3 - 42	7 - 95	-	✓	-	-
NE 24 x 1,5	M 24 x 1,5	M 24 x 1.5	10 - 50	0.39 - 1.97	11 - 170	25 - 382	-	✓	-	-
NE 24 x 1,5	M 24 x 1,5	M 24 x 1.5	60 - 125	2.36 - 4.92	11 - 170	25 - 382	-	✓	✓	-
NG 24 x 1,5	M 24 x 1,5	M 24 x 1.5	10 - 50	0.39 - 1.97	11 - 170	25 - 382	-	✓	-	-
NG 24 x 1,5	M 24 x 1,5	M 24 x 1.5	60 - 100	2.36 - 3.94	11 - 170	25 - 382	-	✓	✓	-



HOW TO ORDER

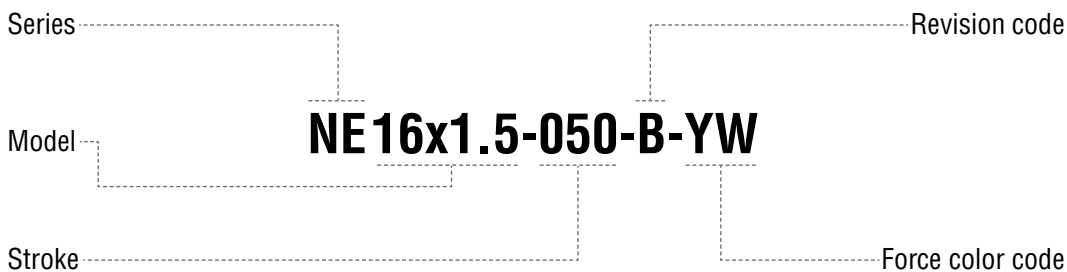

Available versions



NE 16x1.5-050-B-YW

Standard code



Self contained

NE 16 x 1.5

VDI 3004

W-DX35-60M (Ford)

39D 549 (VW)



ACTIVE SAFETY



USAS

* $F_{1i} =$

Isothermal end force at 100% Cu



p. 16



** $F_{1p} =$

Polytropic end force at 100% Cu

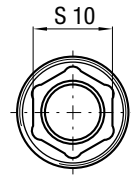
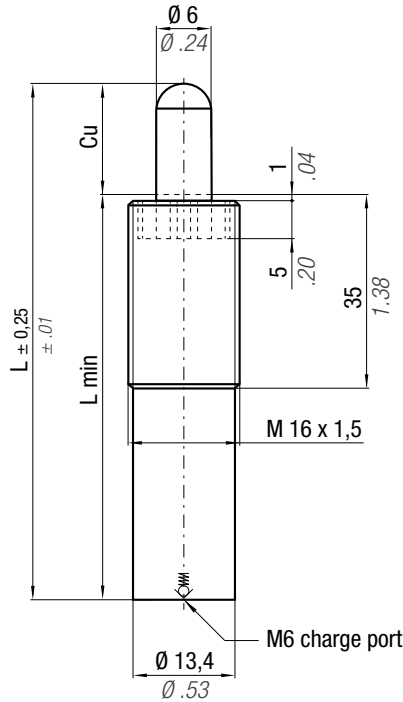

cod. 39CM01A (optional)

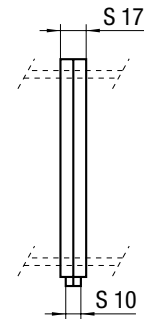

CODE	Cu		L		L min		~Kg		~lb		PED 2014/68/EU	Force color code	P		F ₀ Initial force ± 5%		F _{1i} End force*	F _{1p} End force**	
	mm	inch	mm	inch	mm	inch			bar	psi			daN	lb	+20°C	+68°F			
NE 16 x 1,5-010-B-...	10	0.39	65	2.56	55	2.17	0,05	0.11	✓										
NE 16 x 1,5-020-B-...	20	0.79	85	3.35	65	2.56	0,06	0.13	✓										
NE 16 x 1,5-030-B-...	30	1.18	105	4.13	75	2.95	0,07	0.15	✓										
NE 16 x 1,5-040-B-...	40	1.57	125	4.92	85	3.35	0,07	0.15	✓										
NE 16 x 1,5-050-B-...	50	1.97	145	5.71	95	3.74	0,08	0.18	✓										
NE 16 x 1,5-060-B-...	60	2.36	165	6.50	105	4.13	0,08	0.18	✓										
NE 16 x 1,5-070-B-...	70	2.76	185	7.28	115	4.53	0,09	0.20	✓										
NE 16 x 1,5-080-B-...	80	3.15	205	8.07	125	4.92	0,10	0.22	✓										
NE 16 x 1,5-100-B-...	100	3.94	245	9.65	145	5.71	0,11	0.24	✓										
NE 16 x 1,5-125-B-...	125	4.92	295	11.61	170	6.69	0,12	0.26	✓										

P = nominal charging pressure

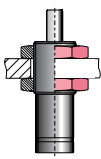

DM 16

HOW TO ORDER

p. 31

INSTALLATION GUIDELINE

p. 205

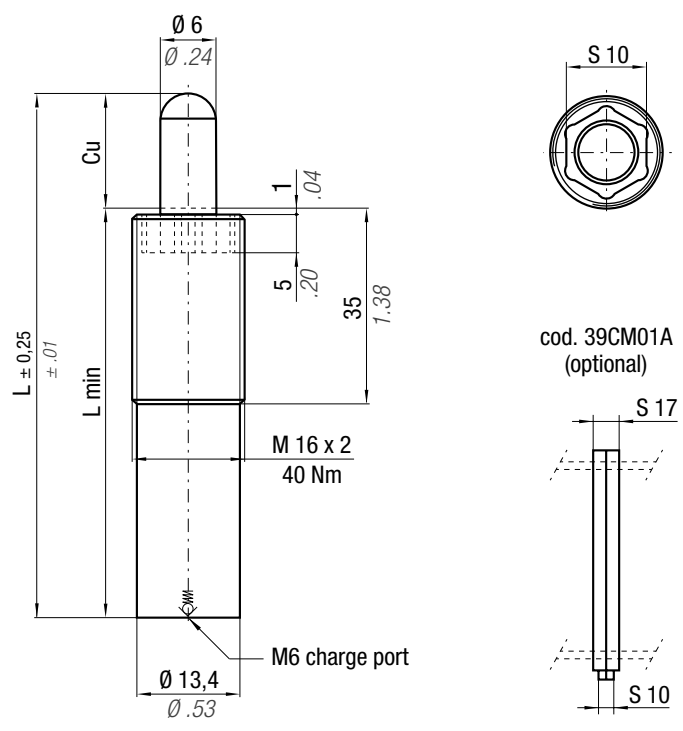

cod. 39CM01A (optional)

* F_{1i} = Isothermal end force at 100% Cu p. 16 F_{1p} = Polytrophic end force at 100% Cu

ACTIVE SAFETY



CODE	Cu		L		L min		S		SPM	Max Speed	Maintenance kit
	mm	inch	mm	inch	mm	inch	~Kg	~lb			
NE 16 x 2-010-B-...	10	0.39	65	2.56	55	2.17	0,05	0.11	~ 50 - 100 (at 20°C)	1,8 m/s 70.8 in/s	Disposable
NE 16 x 2-020-B-...	20	0.79	85	3.35	65	2.56	0,06	0.13			
NE 16 x 2-030-B-...	30	1.18	105	4.13	75	2.95	0,07	0.15			
NE 16 x 2-040-B-...	40	1.57	125	4.92	85	3.35	0,07	0.15			
NE 16 x 2-050-B-...	50	1.97	145	5.71	95	3.74	0,08	0.18			
NE 16 x 2-060-B-...	60	2.36	165	6.50	105	4.13	0,08	0.18			
NE 16 x 2-070-B-...	70	2.76	185	7.28	115	4.53	0,09	0.20			
NE 16 x 2-080-B-...	80	3.15	205	8.07	125	4.92	0,10	0.22			
NE 16 x 2-100-B-...	100	3.94	245	9.65	145	5.71	0,11	0.24			
NE 16 x 2-125-B-...	125	4.92	295	11.61	170	6.69	0,12	0.26			

Force color code	P		F ₀ Initial force ± 5%		F _{1i} End force*	F _{1p} End force**
	bar	psi	daN	lb		
PR	12	174	4	9	1,57 x F ₀	2,03 x F ₀
GR	20	290	6	14	1,57 x F ₀	2,03 x F ₀
BU	40	580	11	25	1,57 x F ₀	2,03 x F ₀
RD	75	1088	21	47	1,57 x F ₀	2,03 x F ₀
YW	150	2175	42	95	1,57 x F ₀	2,03 x F ₀
BK	10-150	145-2175	3-42	7-95	1,57 x F ₀	2,03 x F ₀

P = nominal charging pressure

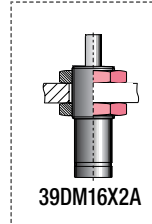

HOW TO ORDER p. 31

INSTALLATION GUIDELINE p. 205

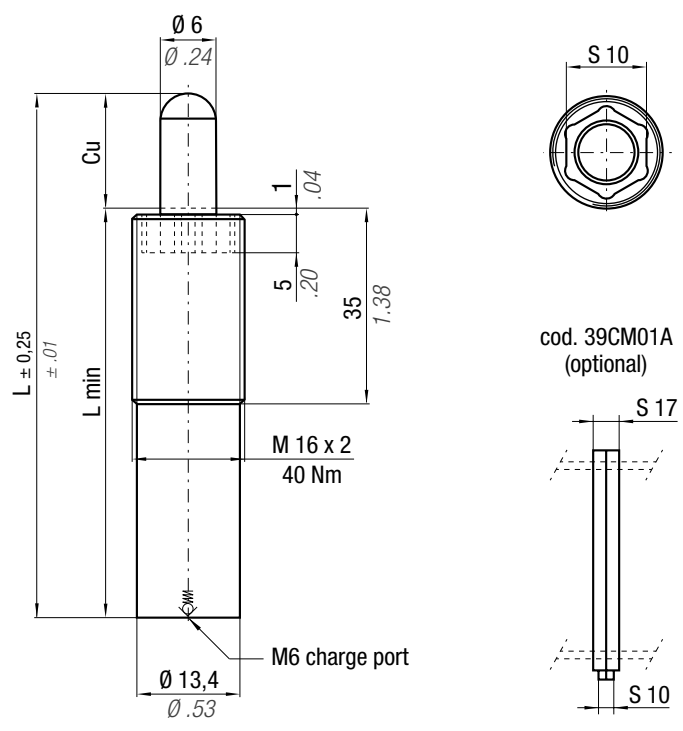

* F_{1i} = Isothermal end force at 100% Cu p. 16

** F_{1p} = Polytropic end force at 100% Cu

ACTIVE SAFETY

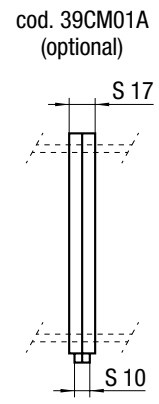

CODE	Cu		L		L min		~Kg ~lb		PED 2014/68/EU	Force color code	P		F ₀ Initial force ± 5% +20°C +68°F		F _{1i} End force*	F _{1p} End force**
	mm	inch	mm	inch	mm	inch	bar	psi			daN	lb				
NE 16 x 2-010-B-...	10	0.39	65	2.56	55	2.17	0,05	0.11	✓	PR	12	174	4	9	1,57 x F ₀	2,03 x F ₀
NE 16 x 2-020-B-...	20	0.79	85	3.35	65	2.56	0,06	0.13	✓	GR	20	290	6	14	1,57 x F ₀	2,03 x F ₀
NE 16 x 2-030-B-...	30	1.18	105	4.13	75	2.95	0,07	0.15	✓	BU	40	580	11	25	1,57 x F ₀	2,03 x F ₀
NE 16 x 2-040-B-...	40	1.57	125	4.92	85	3.35	0,07	0.15	✓	RD	75	1088	21	47	1,57 x F ₀	2,03 x F ₀
NE 16 x 2-050-B-...	50	1.97	145	5.71	95	3.74	0,08	0.18	✓	YW	150	2175	42	95	1,57 x F ₀	2,03 x F ₀
NE 16 x 2-060-B-...	60	2.36	165	6.50	105	4.13	0,08	0.18	✓	BK	10-150	145-2175	3-42	7-95	1,57 x F ₀	2,03 x F ₀
NE 16 x 2-070-B-...	70	2.76	185	7.28	115	4.53	0,09	0.20	✓							
NE 16 x 2-080-B-...	80	3.15	205	8.07	125	4.92	0,10	0.22	✓							
NE 16 x 2-100-B-...	100	3.94	245	9.65	145	5.71	0,11	0.24	✓							
NE 16 x 2-125-B-...	125	4.92	295	11.61	170	6.69	0,12	0.26	✓							

P = nominal charging pressure

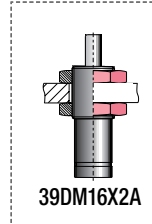

HOW TO ORDER p. 31

INSTALLATION GUIDELINE p. 205

NE 24 x 1.5

VDI 3004

W-DX35-60M (Ford)

39D 549 (VW)



ACTIVE SAFETY



USAS



OPAS

* $F_{1i} =$

Isothermal
end force
at 100% Cu



p. 16



** $F_{1p} =$

Polytrophic
end force
at 100% Cu

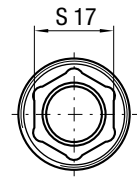
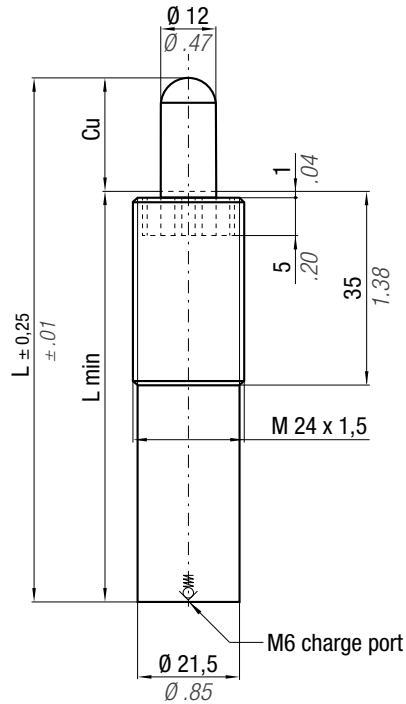

cod. 39CM01A
(optional)

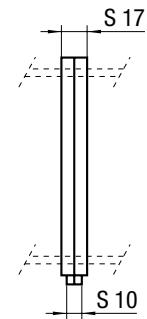

CODE	Cu		L		L min		~Kg		PED 2014/68/EU	Force color code	P		F ₀ Initial force ± 5%		F _{1i} End force*	F _{1p} End force**
	mm	inch	mm	inch	mm	inch	~Kg	~lb			bar	psi	daN	lb		
NE 24 x 1,5-010-B-...	10	0.39	65	2.56	55	2.17	0,16	0.35	✓	GR	20	290	23	52	1,86 x F ₀	2,54 x F ₀
NE 24 x 1,5-020-B-...	20	0.79	85	3.35	65	2.56	0,18	0.40	✓	BU	40	580	45	101	1,86 x F ₀	2,54 x F ₀
NE 24 x 1,5-030-B-...	30	1.18	105	4.13	75	2.95	0,20	0.44	✓	RD	75	1088	85	191	1,86 x F ₀	2,54 x F ₀
NE 24 x 1,5-040-B-...	40	1.57	125	4.92	85	3.35	0,23	0.51	✓	YW	150	2175	170	382	1,86 x F ₀	2,54 x F ₀
NE 24 x 1,5-050-B-...	50	1.97	145	5.71	95	3.74	0,25	0.55	✓	BK	10-150	145-2175	11-170	25-382	1,86 x F ₀	2,54 x F ₀
NE 24 x 1,5-060-B-...	60	2.36	165	6.50	105	4.13	0,27	0.59	✓							
NE 24 x 1,5-070-B-...	70	2.76	185	7.28	115	4.53	0,29	0.64	✓							
NE 24 x 1,5-080-B-...	80	3.15	205	8.07	125	4.92	0,30	0.66	✓							
NE 24 x 1,5-100-B-...	100	3.94	245	9.65	145	5.71	0,33	0.73	✓							
NE 24 x 1,5-125-B-...	125	4.92	295	11.61	170	6.69	0,35	0.77	✓							

P = nominal charging pressure

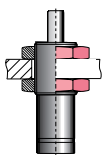

DM 24

HOW TO ORDER

p. 31

INSTALLATION GUIDELINE

p. 205

VDI 3004 90.25.97 (GM)	B2 4036 (BMW) 90.25.28 (GM)	075.90.40 (FCA) 39D 549 (VW)	W-DX35-60M (Ford)
---------------------------	--------------------------------	---------------------------------	-------------------

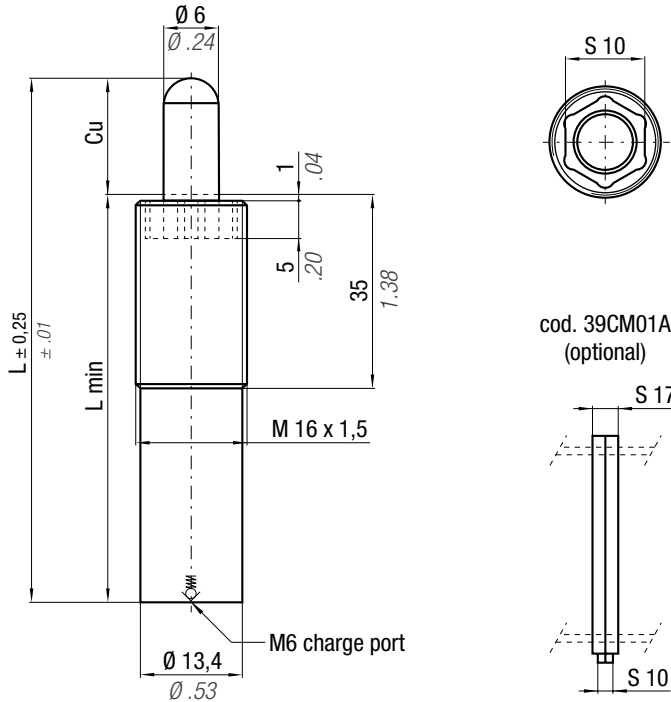

* $F_{1i} =$

Isothermal
end force
at 100% Cu

p. 16

** $F_{1p} =$

Polytropic
end force
at 100% Cu

**ACTIVE
SAFETY**



USAS

cod. 39CM01A
(optional)

CODE	Cu		L		L min		S		SPM ~ 50 - 100 (at 20°C)	Max Speed 1,8 m/s 70.8 in/s	Maintenance kit Disposable
	mm	inch	mm	inch	mm	inch	~Kg	~lb			
NG 16 x 1,5-010-A-...	10	0.39	80	3.15	70	2.76	0,05	0.11	0,28 cm ² 0.043 in ²	~ 50 - 100 (at 20°C)	Disposable
NG 16 x 1,5-020-A-...	20	0.79	100	3.94	80	3.15	0,06	0.13			
NG 16 x 1,5-030-A-...	30	1.18	120	4.72	90	3.54	0,07	0.15	0,28 cm ² 0.043 in ²	~ 50 - 100 (at 20°C)	Disposable
NG 16 x 1,5-040-A-...	40	1.57	140	5.51	100	3.94	0,07	0.15			
NG 16 x 1,5-050-A-...	50	1.97	160	6.30	110	4.33	0,08	0.18	0,28 cm ² 0.043 in ²	~ 50 - 100 (at 20°C)	Disposable
NG 16 x 1,5-060-A-...	60	2.36	180	7.09	120	4.72	0,08	0.18			
NG 16 x 1,5-070-A-...	70	2.76	200	7.87	130	5.12	0,09	0.20	0,28 cm ² 0.043 in ²	~ 50 - 100 (at 20°C)	Disposable
NG 16 x 1,5-080-A-...	80	3.15	220	8.66	140	5.51	0,10	0.22			
NG 16 x 1,5-100-A-...	100	3.94	260	10.24	160	6.30	0,11	0.24	0,28 cm ² 0.043 in ²	~ 50 - 100 (at 20°C)	Disposable

P = nominal charging pressure

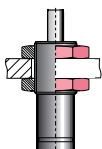

DM 16

HOW TO ORDER

p. 31

INSTALLATION GUIDELINE

p. 205

NG 24 x 1.5

VDI 3004 90.25.96 (GM)	075.90.40 (FCA) 39D 549 (VW)	W-DX35-60M (Ford)	90.25.95 (GM)
---------------------------	---------------------------------	-------------------	---------------



ACTIVE SAFETY



USAS



OPAS

* $F_{1i} =$

Isothermal
end force
at 100% Cu



p. 16



** $F_{1p} =$

Polytropic
end force
at 100% Cu

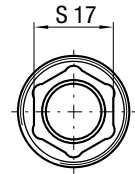
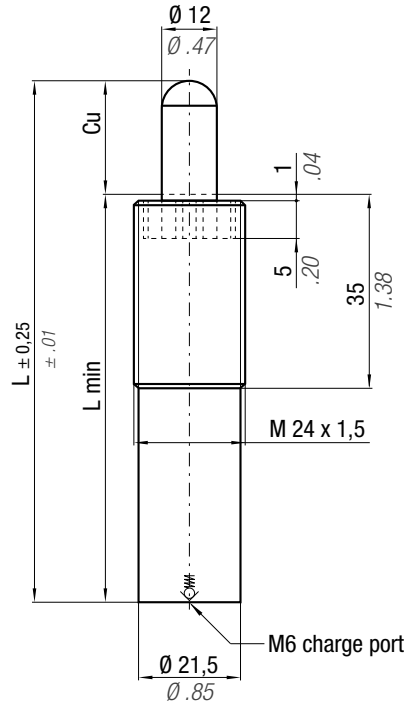

cod. 39CM01A
(optional)

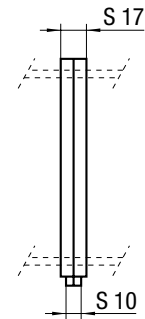

CODE	Cu		L		L min		~Kg		~lb	PED 2014/68/EU	Force color code	P		F ₀ Initial force ± 5%		F _{1i} End force*	F _{1p} End force**
	mm	inch	mm	inch	mm	inch	bar	psi				daN	lb				
NG 24 x 1,5-010-A-...	10	0.39	80	3.15	70	2.76	0,15	0.33	✓								
NG 24 x 1,5-020-A-...	20	0.79	100	3.94	80	3.15	0,17	0.37	✓								
NG 24 x 1,5-030-A-...	30	1.18	120	4.72	90	3.54	0,19	0.42	✓								
NG 24 x 1,5-040-A-...	40	1.57	140	5.51	100	3.94	0,22	0.49	✓								
NG 24 x 1,5-050-A-...	50	1.97	160	6.30	110	4.33	0,24	0.53	✓								
NG 24 x 1,5-060-A-...	60	2.36	180	7.09	120	4.72	0,26	0.57	✓								
NG 24 x 1,5-070-A-...	70	2.76	200	7.87	130	5.12	0,28	0.62	✓								
NG 24 x 1,5-080-A-...	80	3.15	220	8.66	140	5.51	0,29	0.64	✓								
NG 24 x 1,5-100-A-...	100	3.94	260	10.24	160	6.30	0,31	0.68	✓								

P = nominal charging pressure

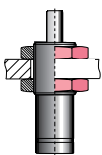

DM 24

HOW TO ORDER

p. 31

INSTALLATION GUIDELINE

p. 205